



Research Report

Attachment of Windows with Integral Flanges Through Foam Plastic Insulating Sheathing to Wood Framing

DRR No. 1304-01

Foam Sheathing Committee (FSC) Members

Issue Date: August 29, 2013

Updated: June 12, 2015

Atlas Roofing Corporation – atlasroofing.com, atlaswallci.com, atlaseps.com
Dow Building Solutions – building.dow.com
GAF – gaf.com
Hunter Panels – hpanels.com
Johns Manville – jm.com
Kingspan Insulation, LLC – kingspan.com
Owens Corning – owenscorning.com
Rmax Operating, LLC – rmax.com

DIVISION: 06 00 00 – WOOD, PLASTICS, AND COMPOSITES

Section: 06 16 00 – Sheathing

DIVISION: 07 00 00 – THERMAL AND MOISTURE PROTECTION

Section: 07 21 00 – Building Insulation

1. Code Compliance Process Evaluated:

- 1.1. The practice of installing windows with the integral flanges placed over code-compliant foam plastic insulating sheathing (FPIS)
 - 1.1.1. Fasteners are attached through the pre-punched nail slots or holes in the window flanges, through the FPIS, and into the window opening framing members.
 - 1.1.2. This research report is intended to supplement the window manufacturer's installation instructions, where installation over foam sheathing is not specifically addressed, or, where addressed, as an alternative method of installation based on a commonly accepted field practice as described in [Section 1.1.1](#).
- 1.2. For the most recent version of this report, visit drjengineering.org. For more detailed state professional engineering and code compliance legal requirements and references, visit drjengineering.org/statelaw. DrJ is fully compliant with all state professional engineering and code compliance laws.

DrJ Research Report

2. Applicable Codes and Standards:¹

- 2.1. 2009, 2012 and 2015 International Building Code (IBC)
- 2.2. 2009, 2012 and 2015 International Residential Code (IRC)
- 2.3. AAMA 2400 – Standard Practice for Installation of Windows with a Mounting Flange in Stud Frame Construction
- 2.4. AAMA A440 – Standard/Specification for Windows, Doors and Unit Skylights
- 2.5. National Design Specification for Wood Construction (NDS)
- 2.6. American Wood Council – Technical Report 12, General Dowel Equations for Calculating Lateral Connection Values
- 2.7. ANSI FS100 – Standard Requirements for Wind Pressure Resistance of Foam Plastic Insulating Sheathing Used in Exterior Wall Covering Assemblies
- 2.8. ASTM C578 – Standard Specification for Rigid, Cellular Polystyrene Thermal Insulation
- 2.9. ASTM C1289 – Standard Specification for Faced Rigid Cellular Polyisocyanurate Thermal Insulation Board
- 2.10. ASTM E330 – Standard Test Method for Structural Performance of Exterior Windows, Doors, Skylights and Curtain Walls by Uniform Static Air Pressure Difference

3. Evaluation Scope:

- 3.1. The testing that serves as the basis of this evaluation is limited to one manufacturer, model, and size of window.
 - 3.1.1. As such, this evaluation is intended as a proof of concept only and is not intended to be used as the sole means of approving a specific product for this application.
- 3.2. The intent of this research report is to provide proof of concept information regarding the ability of FPIS to serve as the sheathing layer installed directly behind window flanges. Due to the vast array of window manufacturers, window types, weights, attachment methods, etc., the window manufacturer should be consulted to confirm applicability with a specific window product or installation condition.
- 3.3. This research report examines the following structural aspects of the tested assemblies:
 - 3.3.1. Ability of the window flanges to support the weight of the window itself.
 - 3.3.2. Ability of the fasteners to support the weight of the window.
 - 3.3.3. Ability to limit deflection of the fasteners (cantilevered through foam and into the framing) to 0.015"².
 - 3.3.4. Ability of the windows to resist transverse wind loading when installed over foam sheathing per ASTM E330.
 - 3.3.5. The following items related to window performance are outside the scope of this research report. However, many of these attributes are addressed in other testing and documentation. See individual manufacturer data for these attributes:
 - 3.3.5.1. Protection from wind-borne debris where required in accordance with [IRC Section R612.6](#).³
 - 3.3.5.2. Performance of glazing installed within the window and door assemblies.
 - 3.3.5.3. Air infiltration.
 - 3.3.5.4. Water penetration and flashing details; refer to [DRR No. 1205-05](#) for conceptual construction details.
- 3.4. Any code compliance issues not specifically addressed in this section are outside the scope of this evaluation.

¹ Unless otherwise noted, all references in this research report are from the 2012 version of the codes and the standards referenced therein, including, but not limited to, ASCE 7, SDPWS and WFCM. This product also complies with the 2000-2009 and 2015 versions of the IBC and IRC and the standards referenced therein. As required by law, where this research report is not approved, the building official shall respond in writing, stating the reasons this research report was not approved.

² This 0.015" deflection limit is consistent with the basis of fastener shear design as applied in the NDS.

³ [2015 IRC Section R609.6](#)

DrJ Research Report

4. Product Description and Materials:

- 4.1. The window selected for this study was a Crestline, Select 200 series, single hung window⁴.
- 4.1.1. This is a vinyl window with integral flanges.
 - 4.1.2. The actual window dimensions are 29½" wide x 41½" tall, fitting a rough opening of 30" wide x 42" tall.
 - 4.1.3. The flange width is 1.98"
 - 4.1.4. The flange thickness is 0.06".
 - 4.1.5. The total window weight is 27.2 lbs.
- 4.2. Members of the American Chemistry Council's Foam Sheathing Committee (FSC) and the trade names of their products that meet the minimum requirements for the FPIS in this research report for use in this application are listed below.⁵
- 4.2.1.1. Atlas Roofing Corporation – “Energy Shield[®]”, “EnergyShield[®] PRO” and “EnergyShield[®] PRO 2”, “Rboard[®] Pro” and “Rboard[®]”, “ThermalStar[®]-CVT”, “ThermalStar[®] LCi”, “ThermalStar[®] LCi-SS”, “ThermalStar[®] Chrome” and “ThermalStar[®] XTR T&G”
2000 River Edge Parkway, Suite 800
Atlanta, GA 30328
800-388-61348
 - 4.2.1.2. Dow Chemical Company – “Super TUFF-R[™]”, “ THERMAX[™]” and “STYROFOAM[™]”
1605 Joseph Drive
Midland, MI 48674
989-638-8655
 - 4.2.1.3. GAF – “EnergyGuard[™] POLYISO INSULATED SHEATHING”
1361 Alps Road
Wayne, New Jersey 07470
973-628-3000
 - 4.2.1.4. Hunter Panels – “Xci Foil”, “Xci CG”, “Xci Class A”, “Xci 286” and “Xci Ply”
15 Franklin Street
Portland, ME 04101
888-746-1114
 - 4.2.1.5. Johns Manville – “AP Foil Faced Foam Sheathing”
P. O. Box 5108
Denver, CO 80217-5108
303-978-2000
 - 4.2.1.6. Kingspan Insulation, LLC
2100 RiverEdge Parkway, Suite 175
Atlanta, GA 30328
678-589-7309
 - 4.2.1.7. Owens Corning – “FOAMULAR[®]”
One Owens Corning Pkwy.
Toledo, OH 43659
419-248-8315
 - 4.2.1.8. Rmax Operating, LLC – “R-Matte[®] Plus-3”, “Thermasheath[®]-3”, “Durasheath-3”, “TSX-8500”, “TSX-8510”, “ECOMAXci” and “Thermasheath-SI”
13524 Welch Road
Dallas, TX 75244
972-387-4500

⁴ While selected for this study, the window size and weight are not limiting factors in the evaluation. Performance is based on the fastener performance in the window flange with FPIS behind the flange. Fastener size is selected based on the weight of the window unit, so larger windows could be used with appropriately sized fasteners.

⁵ FPIS Types listed in this research report are minimums having a compressive strength of at least 15 psi in accordance with the referenced ASTM standards. Substitution of products with equal or greater performance shall be permitted in accordance with [Section 6.2](#).

DrJ Research Report

5. Applications:

5.1. The pertinent code sections related to this application are listed below.

5.1.1. *IRC* code sections⁶:

R612.1 General. This section prescribes performance and construction requirements for exterior window and door installed in wall. Windows and doors shall be installed and flashed in accordance with the fenestration manufacturer's written installation instructions. Window and door openings shall be flashed in accordance with Section R703.8⁷. Written installation instructions shall be provided by the fenestration manufacturer for each window or door.

R612.2 Performance. Exterior windows and doors shall be designed to resist the design wind loads specified in Table R301.2(2) adjusted for height and exposure in accordance with Table R301.2(3).

R612.3 Testing and labeling. Exterior windows and sliding doors shall be tested by an *approved* independent laboratory, and bear a *label* identifying manufacturer, performance characteristics and *approved* inspection agency to indicate compliance with AAMA\WDMA\CSA 101/I.S.2/A440. Exterior side-hinged doors shall be tested and *labeled* as conforming to AAMA\WDMA\CSA 101/I.S.2/A440 or comply with Section R612.5.⁸

R612.5 Other exterior window and door assemblies. Exterior windows and door assemblies not included within the scope of Section R612.3⁹ or Section R612.4¹⁰ shall be tested in accordance with ASTM E 330. Glass in assemblies covered by this exception shall comply with Section R308.5.

R612.7.1 Anchoring requirements. Window and glass door assemblies shall be anchored in accordance with the published manufacturer's recommendations to achieve the design pressure specified. **Substitute anchoring systems used for substrates not specified by the fenestration manufacturer shall provide equal or greater anchoring performance as demonstrated by accepted engineering practice. [emphasis added]**

5.1.2. *IBC* code sections¹¹:

1405.13 Exterior windows and doors. Windows and doors installed in exterior walls shall conform to the testing and performance requirements of Section 1710.5.

1405.13.1 Installation. Windows and doors shall be installed in accordance with approved manufacturer's instructions. Fastener size and spacing shall be provided in such instructions and shall be calculated based on maximum loads and spacing used in the tests.

1710.5 Exterior window and door assemblies. The design pressure rating of exterior windows and doors in buildings shall be determined in accordance with Section 1710.5.1 or 1710.5.2

1710.5.1 Exterior windows and doors. Exterior windows and sliding doors shall be tested and labeled as conforming to AAMA\WDMA\CSA101/I.S.2/A440. The *label* shall state the name of the manufacturer, the *approved* labeling agency and the product designation as specified in AAMA\WDMA\CSA101/I.S.2/A440. Exterior side-hinged doors shall be tested and *labeled* as conforming to AAMA\WDMA\CSA101/I.S.2/A440 or comply with Section 1710.5.2¹². Products tested and labeled as conforming to AAMA\WDMA\CSA101/I.S.2/A440 shall not be subject to the requirements of Sections 2403.2 and 2403.3.

1710.5.2¹³ Exterior windows and door assemblies not provided for in Section 1710.5.1¹⁴. Exterior window and door assemblies shall be tested in accordance with ASTM E 330. Structural performance of garage doors and rolling doors shall be determined in accordance with either ASTM E 330 or ANSI/DASMA 108, and shall meet the acceptance criteria of ANSI/DASMA 108. Exterior window and door assemblies containing glass shall comply with Section 2403. The design pressure for testing shall be calculated in accordance with Chapter 16. Each assembly shall be tested for 10 seconds at a load equal to 1 ½ times the design pressure.

5.2. Testing window assemblies for gravity loads is not specifically required by the building codes.

5.2.1. Manufacturer installation instructions generally require that the window be fully supported at the sill.

⁶ [2015 IRC Section R609](#)

⁷ [2015 IRC Section R703.4](#)

⁸ [2015 IRC Section R609.5](#)

⁹ [2015 IRC Section R609.3](#)

¹⁰ [IRC Section R612.4 \(2015 IRC Section R609.4\)](#) addresses garage doors, which are outside the scope of this research report.

¹¹ [2015 IBC Section 1709.5](#)

¹² [2015 IBC Section 1709.5.2](#)

¹³ [2015 IBC Section 1709.5.2](#)

¹⁴ [2015 IBC Section 1709.5.1](#)

DrJ Research Report

- 5.2.2. As a result, the manufacturer's installation instructions and the building codes are mainly concerned with transverse wind loading and the ability of the assemblies to maintain the integrity of the building envelope in resisting penetration by wind-driven rain.
- 5.3. Depending on a number of factors, including the presence of a sloped sill surface for drainage or the presence of thick foam sheathing, it may be difficult or impractical to provide full support for gravity loads of the window assembly by means of a sill directly supporting the window frame (see [Figure 1](#)).
- 5.3.1. For the application evaluated in this research report, the window frame is to some extent cantilevered outside the framing (depending on the thickness of the FPIS layer), with a worst-case assumption that support of the assembly is provided only by the fasteners extending through the window flange and FPIS into the framing.

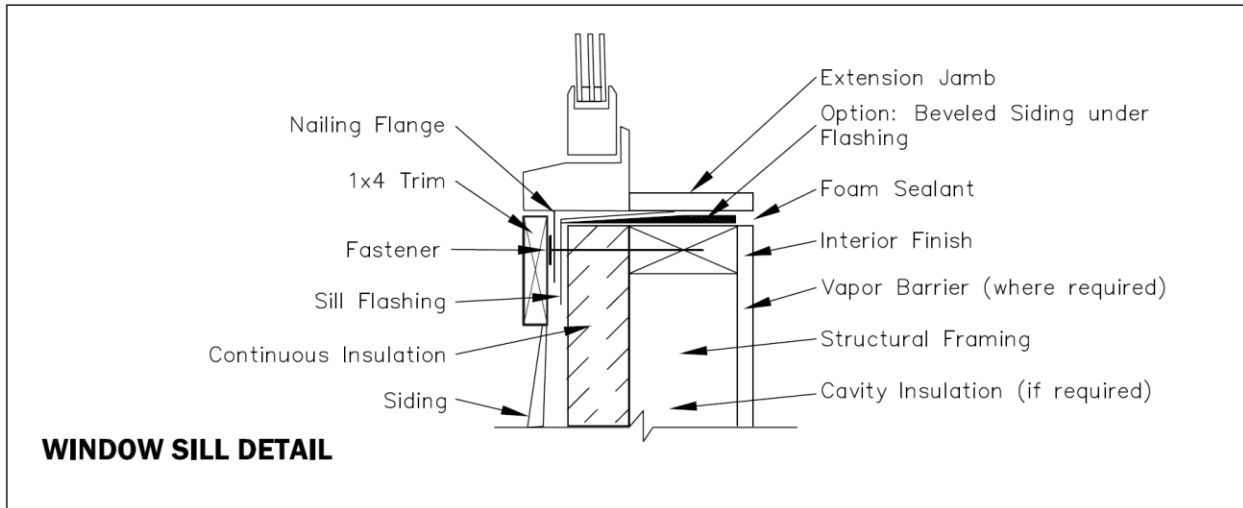

Figure 1: Window Sill Detail

- 5.4. As a result, FSC commissioned confirmatory testing to gain an understanding of the performance of a representative integral-flange window with characteristics as described in [Section 4.1](#) when installed over a layer of FPIS meeting the minimum 15 psi compressive strength requirement of [Section 4.2](#).
- 5.5. FPIS consisting of XPS, Type X (compressive strength of 15 psi) was selected as a representative product for the confirmatory testing by SBCRI.
- 5.5.1. Three series of tests were undertaken.
- 5.5.1.1. Series 1: Measurement of the long-term vertical deflection of a typical integral-flanged window with respect to the wall framing (see [Photo 1](#))



Photo 1: Long-Term Deflection Under Self-Weight Testing

DrJ Research Report

5.5.1.2. Series 2: Proof tests to verify that the calculations used to specify fasteners and to limit deflection to 0.015" are accurate (see [Photo 2](#))



Photo 2: Structural Loading – Fastener/Flange Capacity

5.5.1.3. Series 3: *ASTM E330* wind pressure testing to confirm resistance to wind loads of a typical integral-flanged window installed over FPIS with those installed directly to framing (see [Photo 3](#))



Photo 3: Wind Pressure Loading Test Setup

5.6. Series 1: SBCRI testing to measure resistance to long-term deflection under self-weight

5.6.1. Three identical window frames were constructed. Windows were purchased locally and attached as follows:

5.6.1.1. All wall framing assemblies were constructed in accordance with the fastening requirements of [IRC Table R602.3\(1\)](#).

5.6.1.2. The sill of the rough opening was not installed, so that no support was provided for the window other than through the fastening of the window side and top flanges. All fasteners were 0.120" diameter. 1 3/4" fasteners were used for the installation with no FPIS, 3" fasteners for the installation with 1" FPIS, and 3 1/2" fasteners for the installation with 2" of FPIS. Also, no shims or supplemental anchoring devices were installed.

DrJ Research Report

5.6.1.3. String pots were installed to measure the deflection at the lower corners of the window in relation to the base of the assembly.

5.6.1.4. Assembly 1: Window was attached directly to the rough opening.

5.6.1.5. Assembly 2: Layer of 1" FPIS was installed over the framing, and the window was installed with the fasteners extending through the FPIS and into the wood framing.

5.6.1.6. Assembly 3: Layer of 2" FPIS was installed over the framing, and the window was installed with the fasteners extending through the FPIS and into the wood framing.

5.6.2. The assemblies are shown in [Photo 1](#). Test results:

5.6.2.1. After two weeks – No significant movement in any of the three assemblies.

5.7. Series 2: Proof tests conducted by SBRCI to verify that the calculations used to specify fasteners and to limit deflection to 0.015" are accurate

5.7.1. Test frames, similar to those in the Series 1 tests, were constructed. As in the earlier tests, one had the window attached through 1" of FPIS, and one had the window attached through 2" of FPIS. An example is shown in [Photo 2](#).

5.7.2. All testing was conducted using mechanical fasteners only as a worst-case installation condition; no sealant/adhesive was used in flange joints, as is normally required or practiced in the field.

5.7.3. All fasteners were 0.120" diameter. 1¾" fasteners were used for the installation with no FPIS, 3" fasteners for the installation with 1" FPIS, and 3½" fasteners for the installation with 2" of FPIS.

5.7.4. In each case, load was applied directly to the head of the window until failure of the window flange or fasteners occurred.

5.7.5. Test results:

5.7.5.1. [Figure 2](#) shows the load deflection plots of the tests through failure. The plots show the average deflection taken from the lower left and lower right corners of the windows during the tests. Both tests reached failure with a load in the range of 3,300-3,600 lbs., showing that the window flanges and fasteners have an ultimate capacity that greatly exceeds the weight of the window and can be designed to support the weight of the windows alone. Further, the connection behavior exhibited significant resiliency and toughness in its ability to sustain load over a range of deflection up through 1½" of window movement.

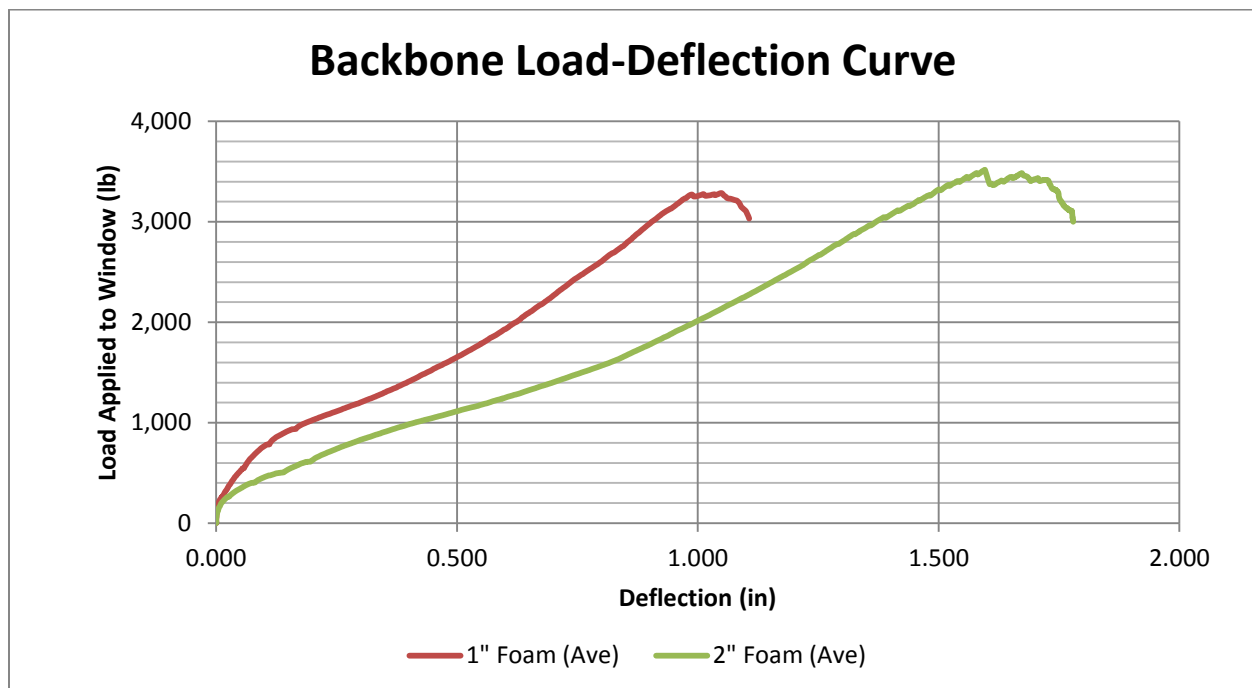

Figure 2: Backbone Load-Deflection Plot

5.7.5.2. [Figure 3](#) shows the loads applied to the test windows through a deflection of 0.016" and the average deflection as measured at the bottom corners of the window.

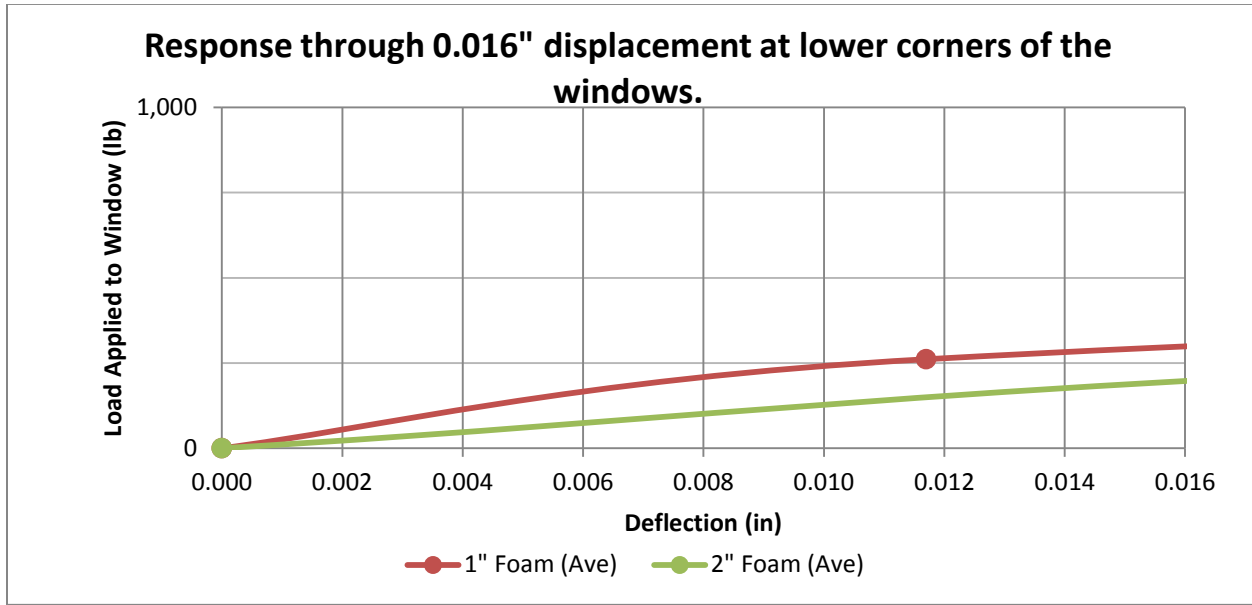

Figure 3: Response to Applied Load Through 0.016" Displacement at Lower Corners of the Windows

5.7.5.3. [Table 1](#) summarizes the structural loading required to achieve 0.015" of deflection and the corresponding load that was applied to each fastener to achieve that deflection.

5.7.5.4. [Table 1](#) also shows the calculated load in accordance with AWC's *Technical Report 12 (TR12)*, Table 1, General Dowel Equations.

5.7.5.4.1. This calculation allows a designer to calculate the lateral resistance of fasteners where a gap exists between the side member load on the fastener and the main framing member.

5.7.5.4.2. In this application, the FPIS is installed in the gap between the side member load on the fastener and the main framing member.

5.7.5.5. This confirms that the calculations in *NDS/TR12* conservatively estimate the deflection and can be used to limit deflection to 0.015" in this application.

FPIS Thickness	Applied Load	Tested Load per Fastener (lbs.)	Load per Fastener Calculated per <i>NDS/TR12</i> (lbs.) ¹
2"	158	6	5
1"	280	10.7	9

1. The allowable load for these fasteners was calculated using a reduction factor of 3, versus the reduction factor of 2.2 as allowed by *NDS/TR12*, providing a higher factor of safety.

Table 1: Test Results Comparing Tested Load per Fastener with the Calculated Load to Limit Deflection to 0.015"

5.8. Series 3: *ASTM E330* wind pressure testing to compare the resistance to wind loads of windows installed over FPIS

5.8.1. An assembly with a window unit was built to the requirements of *ASTM E330* and tested with 2" of FPIS applied. The test setup is shown in [Photo 3](#).

DrJ Research Report

5.8.1.1. [Table 2](#) summarizes the maximum wind pressure experienced by the wall.

Wall Type	Minimum Structural Pressure Rating (STP)	Failure Load (psf)
2" Foam Sheathing	37.5	118

Table 2: Summary of Wind Pressure Test Results

5.8.1.2. The windows used in this test had a minimum design pressure (DP) rating of +/- 25 psf and a minimum structural pressure (STP) of +/-37.5 psf.

5.8.1.3. The 2" FPIS test showed significant excess capacity with respect to the code-compliant wind pressure rating for the window unit.

5.8.1.4. In addition, the tests were conducted without shims applied to jambs at the location of cross rails or any other support than the fastening of the flange through foam sheathing to the jamb studs.

6. Installation:

6.1. Proposed General Installation Requirements for Window Flange Fasteners

6.1.1. Attach to the wall framing in accordance with the more stringent of:

6.1.1.1. The window manufacturer's installation instructions.

6.1.1.2. The minimum fastener size and maximum spacing for attachment of windows through FPIS and into the window opening framing as required by [Table 3](#).

6.1.2. As an alternative to [Section 6.1.1](#), alternate means and methods may be used, where approved by the building official.

6.1.3. Minimum penetration of the fastener into wood framing shall be 1¼".

6.1.4. Minimum lumber shall have a specific gravity (SG) of 0.42 (SPF).

6.1.5. In no case shall fasteners be spaced greater than 16" o.c., per *AAMA 2400*.

6.1.6. Fastener head shall be driven flush with the surface of the window flange for a snug and smooth fit against the foam sheathing.

6.1.7. Care shall be taken to avoid overdriving the fasteners.

6.2. General Requirements for FPIS

6.2.1. Minimum compressive strength – 15 psi

6.2.2. Maximum foam thickness – 2"

6.2.3. Compliant with *ASTM C578* or *ASTM C1289*, as applicable

Minimum Fastener (or equal)	Thickness of Foam Sheathing (in.)	Maximum Fastener Spacing in Flanges per Width of Window Unit	
		≤ 3'	> 3'
0.120"-Diameter Roofing Nail	½"	16" o.c.	9" o.c.
	1"	10" o.c.	5" o.c.
	1½"	7" o.c.	3.5" o.c.
	2"	6" o.c.	3" o.c.

1. Values assume integral flanges with fasteners that support 100% of window unit weight even when sill shims are installed per the manufacturer's installation instructions.
 2. Table is based on a window unit weight of 7 pounds per square foot. For different weights, multiply fastener spacing by 7/w, where w is the actual weight in pounds per square foot.
 3. The fastener spacings provided in this table are the maximum allowed, based on support of the window unit's weight.
 4. For wind load resistance, a lesser fastener spacing may be specified in the window manufacturer's installation instructions.
 5. The window manufacturer's installation instructions, where more stringent, shall be followed, in the event of any conflict.
 6. Spacing calculations in table assume that vertical flanges support 100% of the gravity load.

Table 3: Minimum Fastener Size & Maximum Spacing Along Window Flanges for Attachment to Wood Framing Through FPIS

DrJ Research Report

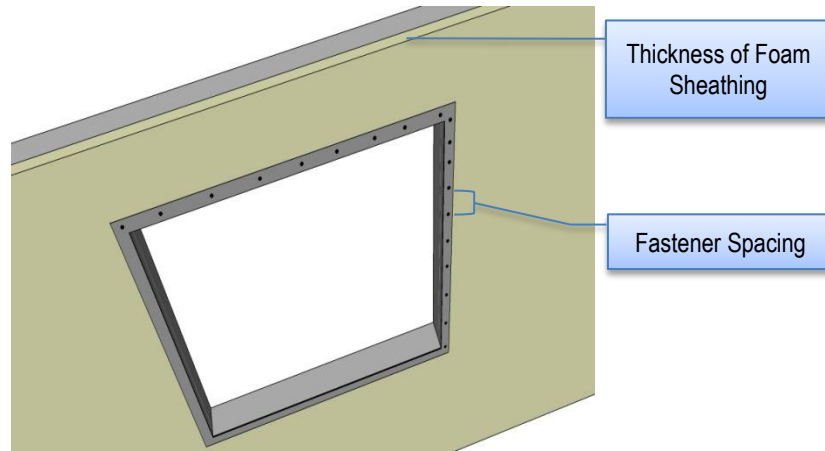

Figure 4: Window Installation Over FPIS

7. Test and Engineering Substantiating Data:

- 7.1. FSC [DRR No. 1205-05](#): *Construction Details for the Use of Foam Plastic Insulating sheathing (FPIS) in Light-Frame Construction.*
- 7.2. FSC [DRR No. 1303-04](#): *Attachment of Exterior Wall Coverings through Foam Plastic Insulating Sheathing (FPIS) to Wood or Steel Wall Framing.*
- 7.3. Test report evaluating the wind pressure resistance of windows installed over FPIS by SBCRI.
- 7.4. Test report evaluating the resistance of fasteners in windows installed over FPIS and OSB by SBCRI.
- 7.5. Test report evaluating creep of fasteners installed into windows over FPIS and OSB by SBCRI.
- 7.6. *Fastening Systems for Continuous Insulation*, New York State Energy Research and Development Authority (NYSERDA), April 2010.
- 7.7. *ASHRAE Journal*, "Installation Requirement for Attachment of Integral Flange-Mounted Window Units Over Foam Plastic Insulating Sheathing", Feb 2013.
- 7.8. *ASHRAE Journal*, "[Windows can be a pain](#)", Lstiburek, April 2015.
- 7.9. Some information contained herein is the result of testing and/or data analysis by other sources, which DrJ relies on to be accurate as it undertakes its engineering analysis.
- 7.10. DrJ has reviewed and found the data provided by other professional sources are credible. This information has been approved in accordance with DrJ's procedure for acceptance of data from approved sources.
- 7.11. DrJ's responsibility for data provided by approved sources is in accordance with professional engineering law.
- 7.12. Where appropriate, DrJ relies on the derivation of design values, which have been codified into law through codes and standards (e.g., *IRC*, *WFCM*, *IBC*, *SDPWS*, etc.). This includes review of code provisions and any related test data that helps with comparative analysis or provides support for equivalency to an intended end-use application.

8. Findings:

- 8.1. When connected in accordance with this research report, fastening is sufficient to limit long-term deflection due to the self-weight of the window assembly.
- 8.2. Proof testing of integral-flanged window assemblies described in this research report confirm the use of [Table 3](#) (based on *NDS/TR12* calculations) for the attachment of windows through FPIS.
- 8.3. Wind pressure tests indicate that integral-flanged windows can be installed over up to 2" of FPIS, even in the absence of shims or special anchors. However, where shims or special anchors are required by the window manufacturer, the window manufacturer's installation instructions shall be followed.

DrJ Research Report

- 8.4. [IBC Section 104.11](#) and [IRC Section R104.11](#) ([IFC Section 104.9](#) is similar) state:

104.11 Alternative materials, design and methods of construction and equipment. The provisions of this code are not intended to prevent the installation of any material or to prohibit any design or method of construction not specifically prescribed by this code, provided that any such alternative has been *approved*. An alternative material, design or method of construction shall be *approved* where the *building official* finds that the proposed design is satisfactory and complies with the intent of the provisions of this code, and that the material, method or work offered is, for the purpose intended, at least the equivalent of that prescribed in this code. ... Where the alternative material, design or method of construction is not *approved*, the *building official* shall respond in writing, stating the reasons the alternative was not *approved*.¹⁵

9. Conditions of Use:

- 9.1. Where required by the authority having jurisdiction (AHJ) in which the project is to be constructed, this report and the window manufacturer's installation instructions shall be submitted at the time of permit application.
- 9.2. These products shall be installed in compliance with the window and FPIS manufacturer's instructions, applicable building code(s) and this research report.
- 9.3. Where the application exceeds the limitations set forth herein, design shall be permitted in accordance with accepted engineering procedures, experience, and good technical judgment.
- 9.4. Design
- 9.4.1. Building Designer Responsibility
- 9.4.1.1. Unless the AHJ allows otherwise, the Construction Documents shall be prepared by a Building Designer (e.g., Owner, Registered Design Professional, etc.) for the Building and shall be in accordance with [IRC Section R106](#) and [IBC Section 107](#).
- 9.4.1.2. The Construction Documents shall be accurate and reliable and shall provide the location, direction and magnitude of all applied loads and shall be in accordance with [IRC Section 301](#) and [IBC Section 1603](#).
- 9.4.2. Construction Documents
- 9.4.2.1. Construction Documents shall be submitted to the Building Official for approval and shall contain the plans, specifications and details needed for the Building Official to approve such documents.
- 9.5. Responsibilities
- 9.5.1. The information contained herein is a product, engineering or building code compliance research report performed in accordance with the referenced building codes, testing and/or analysis through the use of accepted engineering procedures, experience and good technical judgment.
- 9.5.2. DrJ research reports provide an assessment of only those attributes specifically addressed in the Products Evaluated or Code Compliance Process Evaluated section.
- 9.5.3. The engineering evaluation was performed on the dates provided in this research report, within DrJ's professional scope of work.
- 9.5.4. This product is manufactured under a third-party quality control program in accordance with [IRC Section R104.4](#) and [R109.2](#) and [IBC Section 104.4](#) and [110.4](#).
- 9.5.5. The actual design, suitability and use of this research report for any particular building is the responsibility of the Owner or the Owner's authorized agent, and the report shall be reviewed for code compliance by the Building Official.
- 9.5.6. The use of this research report is dependent on the manufacturer's in-plant QC, the ISO/IEC 17020 third-party inspection process, proper installation per the manufacturer's instructions, the Building Official's inspection and any other code requirements that may apply to assure accurate compliance with the applicable building code.

¹⁵ The last sentence is adopted language in the 2015 codes.

DrJ Research Report

10. Identification:

- 10.1. The foam sheathing and windows described in this research report shall be identified by a label bearing the manufacturer's name, product name, label of the third-party inspection agency, and other information to confirm code compliance.

11. Review Schedule:

- 11.1. This research report is subject to periodic review and revision. For the most recent version of this report, visit drjengineering.org.
- 11.2. For information on the current status of this report, contact [DrJ Engineering](#).